



ABB LIMITED
Automation Segment, THAILAND

INSTALLATION PLACE : **EXC**

EQUIPMENT : **CONTROLLER & I/O
DDC.-1/1**

CUSTOMER: **SITE PREPARATION MANAGEMENT Co., Ltd.**

ORDER NO : **TH-25117203**

Sheets :

Item No. :

We reserve all rights in this document and in the information contained therein. Reproduction, use or disclosure to third parties without express authority is strictly forbidden.

File name 3BTH25117203-000A12_A01_R0

Based on	Prepared Chanwit N. / 27-03-18	Title COVER SHEET	= CONTROLLER & I/O CABINET + DDC.-1/1
Customer Site Preparation Management Co., Ltd.	Approved Atchariya K. / 27-03-18		
Cust. Doc. No.	Project name Building Automation System for the Excise Department (EXC)	ABB Limited (Thailand)	Date 27-03-18
ABB Ref. No.			Doc. No. 3BTH25117203-000A12
			Cont. A02

We reserve all rights in this document and in the information contained therein. Reproduction, use or disclosure to third parties without express authority is strictly forbidden.

File name 3BTH25117203-000A12_B01_RO

A
B
C
D
E
F

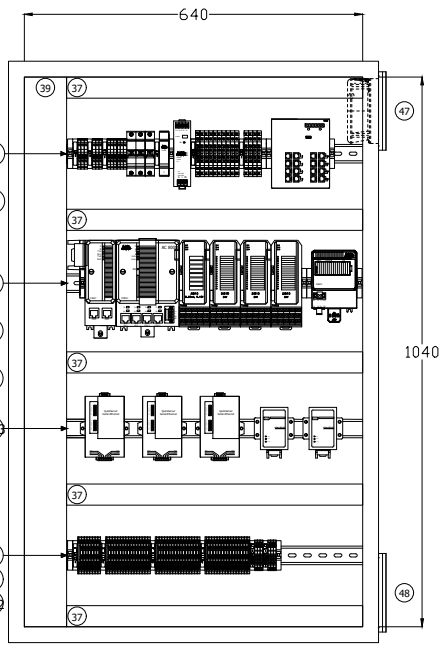
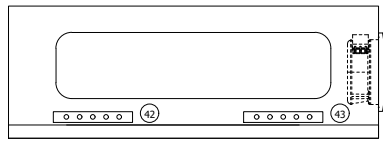

INSIDE VIEW

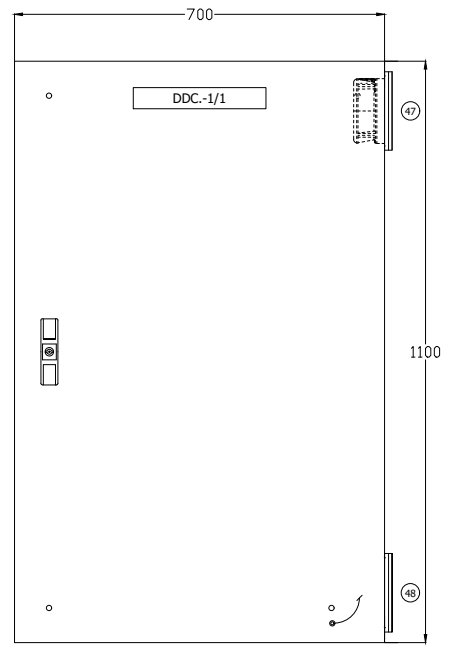

FRONT VIEW

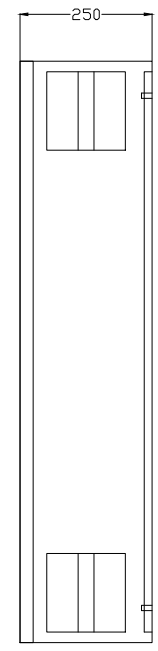

RIGHT SIDE VIEW

CABLE COLOR FOR INTERNAL WIRING		
-Main Supply 220V - Line	Brown	2.5 mm2
-Main Supply 220V - Neutral	Light blue	2.5 mm2
-Ground / Earth	Yellow / Green	2.5 mm2
-Supply Voltage 24Vdc - Plus	Red	1 mm2
-Supply Voltage 24Vdc - Minus	Black	1 mm2
-Sinal - Digital	Blue	0.75 mm2
-Sinal - Analog	White	0.75 mm2
-Lan cable	White	CAT5E

No.	PART NUMBER	QTY	DESCRIPTION
1	S 202M C16	1	Minature circuit breaker 2P 16A, S 202M C16, ABB
2	SH 201 C10	1	Minature circuit breaker 1P 10A, SH 201 C10, ABB
3		1	Fuse terminal 1P 16A, ABB
4	3BSC610065R1	1	Power supply 24VDC 5A, SD832, ABB
5	3BSE018172R1	1	Rechargeable battery unit, SB822, ABB
6		1	CEX-bus terminator, TB850, ABB
7	3BSE008538R1	1	ModuleBus terminator, TB807, ABB
8	3BSE066485R1	1	Processor Unit, PM851, ABB
9	3BSE043660R1	1	Modbus TCP Interface, CI867, ABB
10	3BSE013230R1	4	Compact MTU, TU810V1, ABB
11	3BSE008508R1	3	Digital Input 24V 16 ch, DI810, ABB
12	3BSE008516R1	1	Analog Input 8 ch, AI810, ABB
13	3064085	6	Feed-through terminal block, UT 2.5-MTD, Phoenix Contact
14	3046184	8	Feed-through terminal block, UT 4-MTD, Phoenix Contact
15	3046223	4	Ground terminal block, UT 4-MTD-PE, Phoenix Contact
16	3007204	11	Fuse terminal block, Double-Dect, UKK 5-HESI, Phoenix Contact
17	3044644	56	Disconnect terminal block, UTTB 2,5-TG-P/P, Phoenix Contact
18	3036806	56	Fuse plug, P-FU 5X20, Phoenix Contact
19	3047293	4	End cover, D-UTTB 2,5/4, Phoenix Contact
20	3022218	23	Quick mounting end clamp, CLIPFIX 35, Phoenix Contact
21	1004348	12	Terminal strip markers, KLM-A, Phoenix Contact
22	MB3180	2	1 Port RS-232/422/485 Modbus TCP to Serial Communication Gateway
23	PS-QS-1010-0757	3	Modbus RTU or Modbus TCP/IP to BACnetMS/TP or BACnet/IP, 250 Point
24	943434047	1	Hirschmann, Industrial Unmanaged Ethernet Switch RS20-1600T1T1SDAU
25			
26			
27			
28			
29			
30			
31			
32			
33			
34			
35			
36			
37		3	Cable Duct 40x100, Phoenix Contact
38		-	Cable Duct 60x100, Phoenix Contact
39		1	Cable Duct 80x100, Phoenix Contact
40		-	Cable Duct 100x100, Phoenix Contact
41		1	NS35/15, Din Rail, Phoenix Contact
42		1	PE Copper bar size 20x150mm
43		1	IE Copper bar size 20x150mm
44			
45			
46			
47		1	Fan
48		1	Filter
49			
50			
51			

Based on	Prepared Chanwit N. / 27-03-18
Customer Site Preparation Managemant Co., Ltd.	Approved Atchariya K. / 27-03-18
Cust. Doc. No.	Project name Building Automation System
ABB Ref. No.	for the Excise Department (EXC)

Title	CABINET LAYOUT
ABB ABB Limited (Thailand)	

= CONTROLLER & I/O CABINET + DDC.-1/1	
Resp. dept. IA	Rev. 0
Doc. No.	Date 27-03-18
3BTH25117203-000A12	Sheet B01
	Cont. N101

A
B
C
D
E
F

We reserve all rights in this document and in the information contained therein. Reproduction, use or disclosure to third parties without express authority is strictly forbidden.

File name 3BTH25117203-000A12_N101_RO

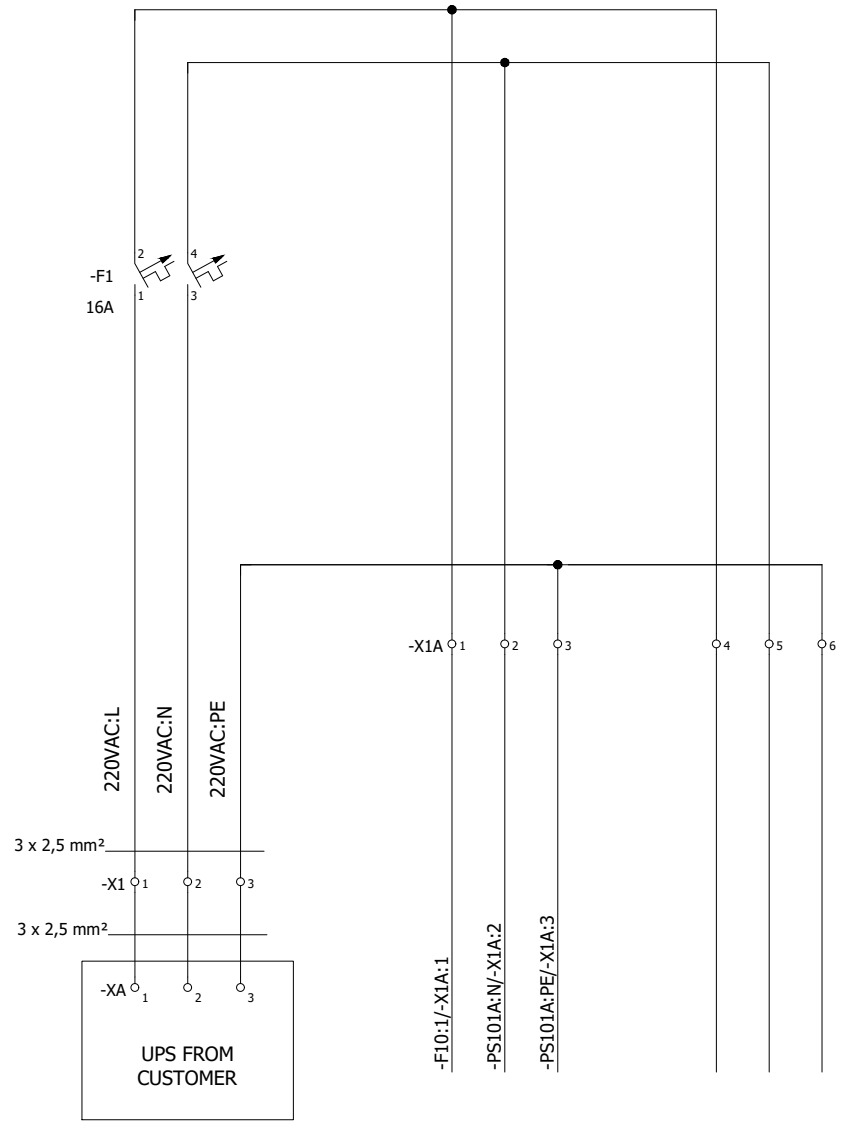

Device	-PS101A	-SPARE
Description	POWER SUPPLY 24 VDC	SPARE

Based on	Prepared Chanwit N. / 27-03-18
Customer Site Preparation Management Co., Ltd.	Approved Atchariya K. / 27-03-18
Cust. Doc. No.	Project name Building Automation System
ABB Ref. No.	for the Excise Department (EXC)

Title	220 VAC POWER DISTRIBUTION
ABB Limited (Thailand)	

= CONTROLLER & I/O CABINET		+ DDC.-1/1	
Resp. dept. IA	Rev. 0	Date	27-03-18
Doc. No.		Sheet	N101
3BTH25117203-000A12		Cont.	N102

We reserve all rights in this document and in the information contained therein. Reproduction, use or disclosure to third parties without express authority is strictly forbidden.

File name 3BTH25117203-000A12_N102_RO

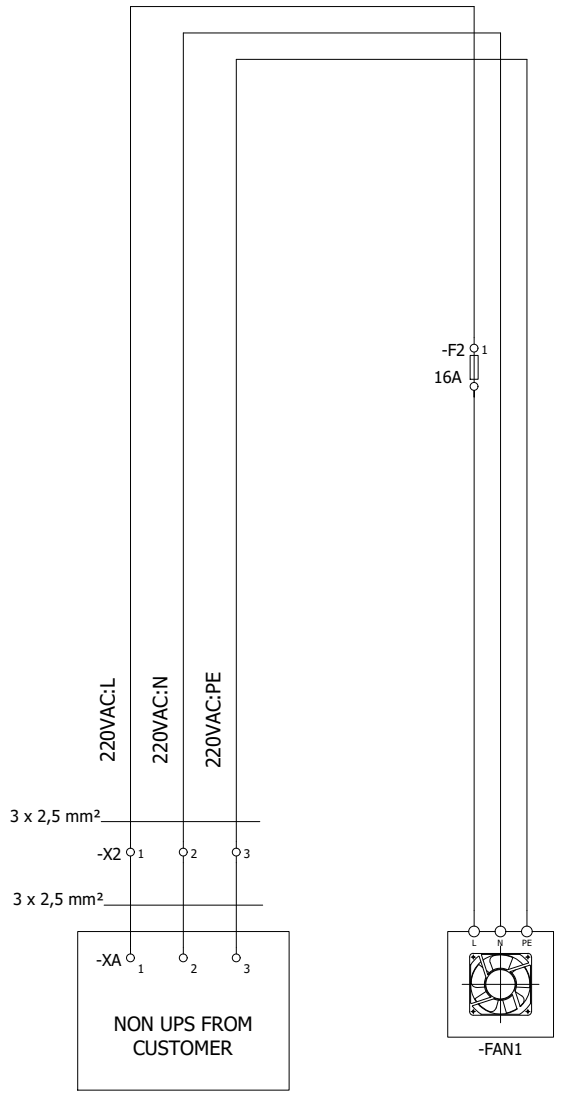

Device	-FAN1
Description	FAN

Based on	Prepared Chanwit N. / 27-03-18
Customer Site Preparation Management Co., Ltd.	Approved Atchariya K. / 27-03-18
Cust. Doc. No.	Project name Building Automation System
ABB Ref. No.	for the Excise Department (EXC)

Title 220 VAC POWER DISTRIBUTION
ABB ABB Limited (Thailand)

= CONTROLLER & I/O CABINET	+ DDC.-1/1	
Resp. dept. IA	Rev. 0	Date 27-03-18
Doc. No. 3BTH25117203-000A12	Sheet N102	Cont. N111

We reserve all rights in this document and in the information contained therein. Reproduction, use or disclosure to third parties without express authority is strictly forbidden.

File name 3BTH25117203-000A12_N111_RO

-X1A:1/-F10:1
 -X1A:2/-PS101A:N
 -X1A:3/-PS101A:PE

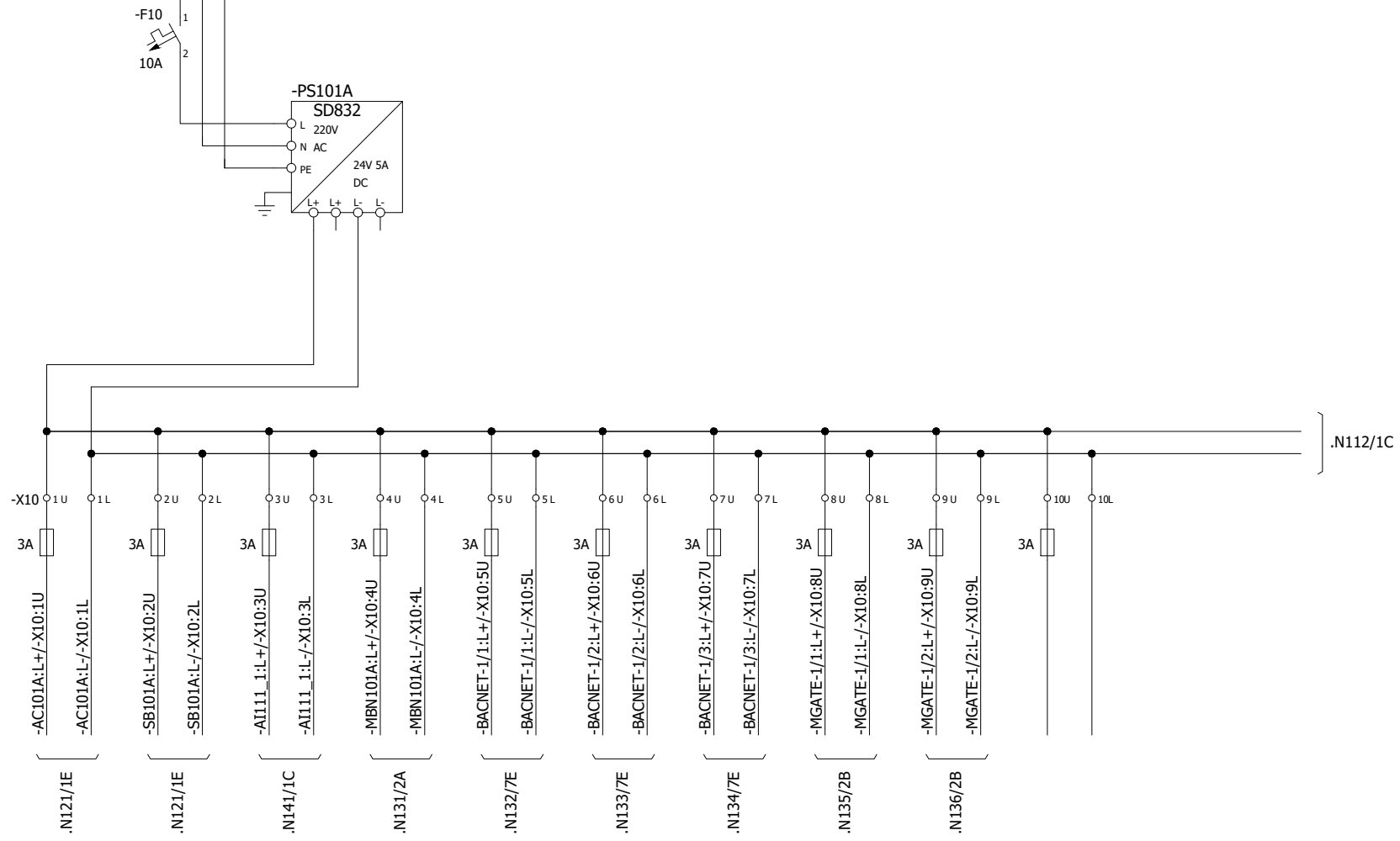

Device	-AC101A	-SB101A	-AI111_1	-MBN101A	-BACNET-1/1	-BACNET-1/2	-BACNET-1/3	MGATE-1/1	MGATE-1/2	SPARE
Description	PM851	SB822	AI810	MODBUS NETWORK SWITCH	BACNET	BACNET	BACNET	MGATE	MGATE	SPARE

Based on	Customer	Prepared	Chanwit N. / 27-03-18
	Site Preparation Management Co., Ltd.	Approved	Atchariya K. / 27-03-18
Cust. Doc. No.		Project name	Building Automation System
ABB Ref. No.			for the Excise Department (EXC)

Title	24VDC POWER DISTRIBUTION
ABB ABB Limited (Thailand)	

= CONTROLLER & I/O CABINET		+ DDC.-1/1	
Resp. dept.	IA	Rev.	0
Doc. No.	3BTH25117203-000A12	Date	27-03-18
		Sheet	N111
		Cont.	N112

We reserve all rights in this document and in the information contained therein. Reproduction, use or disclosure to third parties without express authority is strictly forbidden.

File name 3BTH25117203-000A12_N111_RO

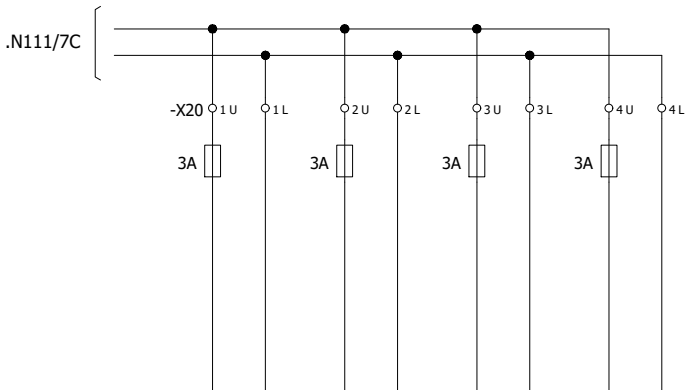

Device	-PS 4W	-PS 4W	-PS 4W	-PS 4W
Description	FIELD INSTRUMENT	FIELD INSTRUMENT	FIELD INSTRUMENT	FIELD INSTRUMENT

Based on	Prepared Chanwit N. / 27-03-18
Customer Site Preparation Management Co., Ltd.	Approved Atchariya K. / 27-03-18
Cust. Doc. No.	Project name Building Automation System
ABB Ref. No.	for the Excise Department (EXC)

Title 24VDC POWER DISTRIBUTION
= CONTROLLER & I/O CABINET + DDC.-1/1
Resp. dept. IA
Doc. No. 3BTH25117203-000A12

ABB ABB Limited (Thailand)

Rev. 0	Date 27-03-18
Sheet N112	Cont. N121

We reserve all rights in this document and in the information contained therein. Reproduction, use or disclosure to third parties without express authority is strictly forbidden.

File name 3BTH25117203-000A12_N121_R0

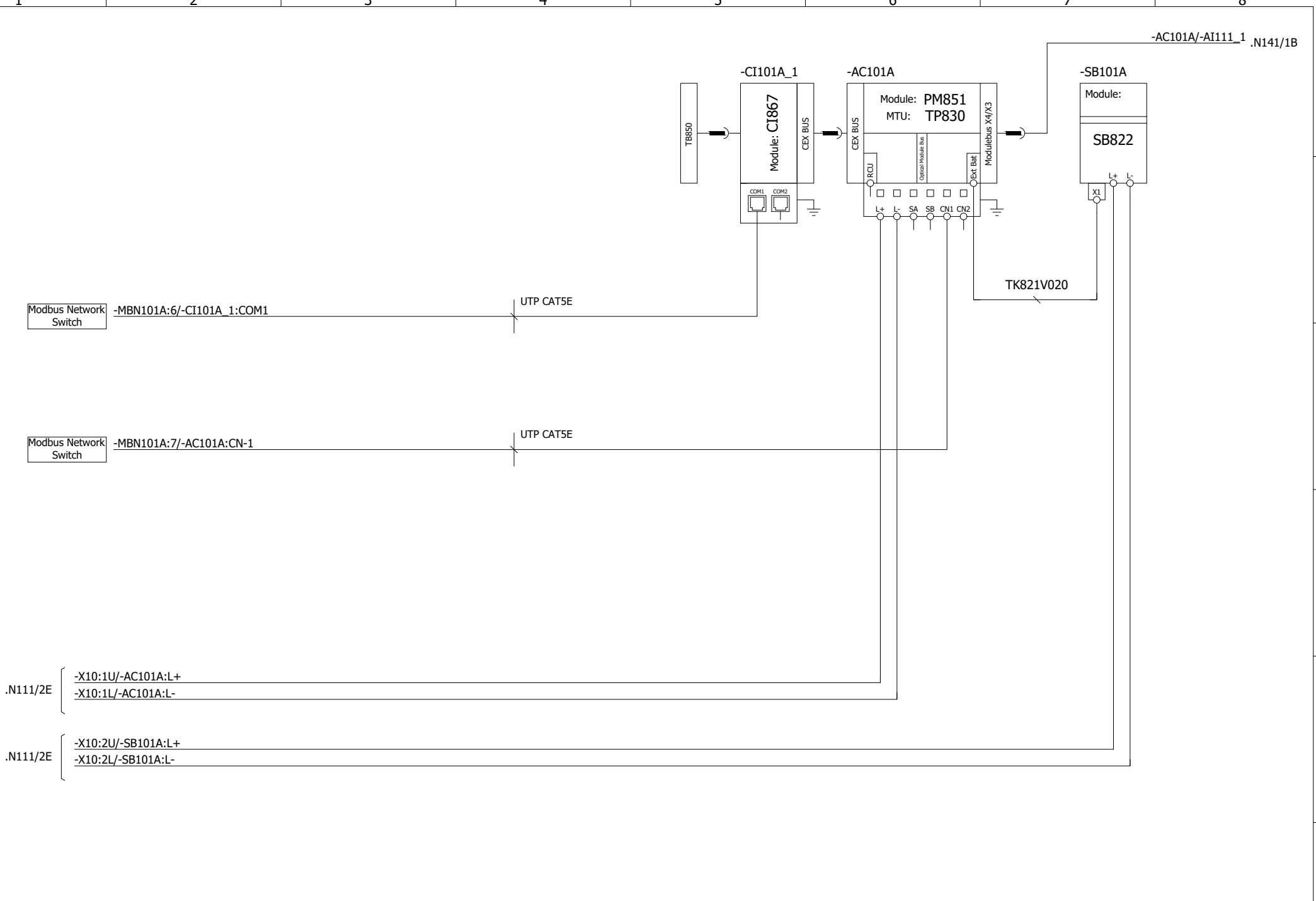

Based on	Prepared Chanwit N. / 27-03-18	Title AC800M Connection	= CONTROLLER & I/O CABINET + DDC.-1/1	
Customer Site Preparation Management Co., Ltd.	Approved Atchariya K. / 27-03-18	 ABB Limited (Thailand)	Resp. dept. IA	Date 27-03-18
Cust. Doc. No.	Project name Building Automation System		Rev. 0	Sheet N121
ABB Ref. No.	for the Excise Department (EXC)		Doc. No. 3BTH25117203-000A12	Cont. N131

We reserve all rights in this document and in the information contained therein. Reproduction, use or disclosure to third parties without express authority is strictly forbidden.

File name 3BTH25117203-000A12_N131_RO

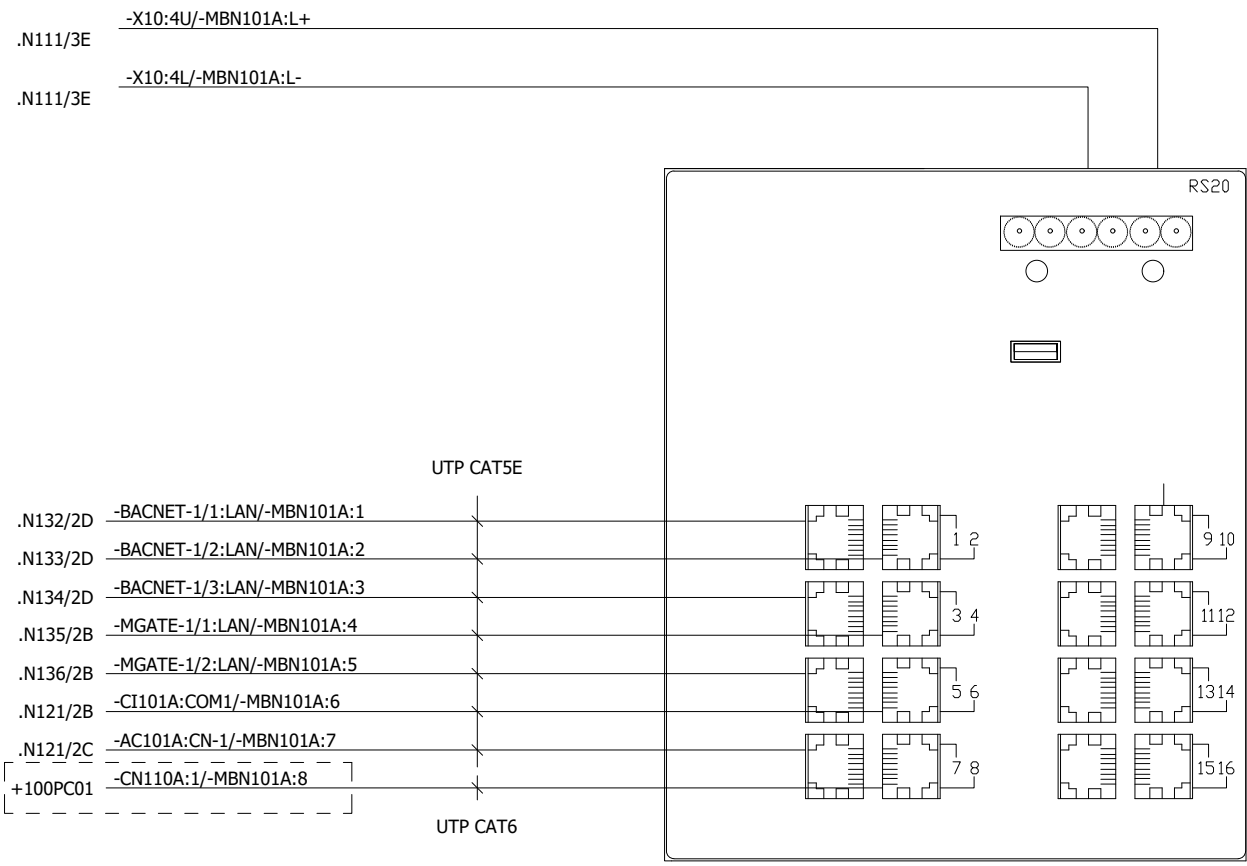

-MBN101A MODBUS NETWORK SWITCH

Based on	Prepared Chanwit N. / 27-03-18	Title MBN101A MODBUS NETWORK SWITCH	= CONTROLLER & I/O CABINET + DDC.-1/1
Customer Site Preparation Management Co., Ltd.	Approved Atchariya K. / 27-03-18	ABB Limited (Thailand)	Resp. dept. IA
Cust. Doc. No.	Project name Building Automation System		Rev. 0
ABB Ref. No.	for the Excise Department (EXC)		Date 27-03-18
			Sheet N131
			Cont. N132
			3BTH25117203-000A12

We reserve all rights in this document and in the information contained therein. Reproduction, use or disclosure to third parties without express authority is strictly forbidden.

File name 3BTH25117203-000A12_N132_R0

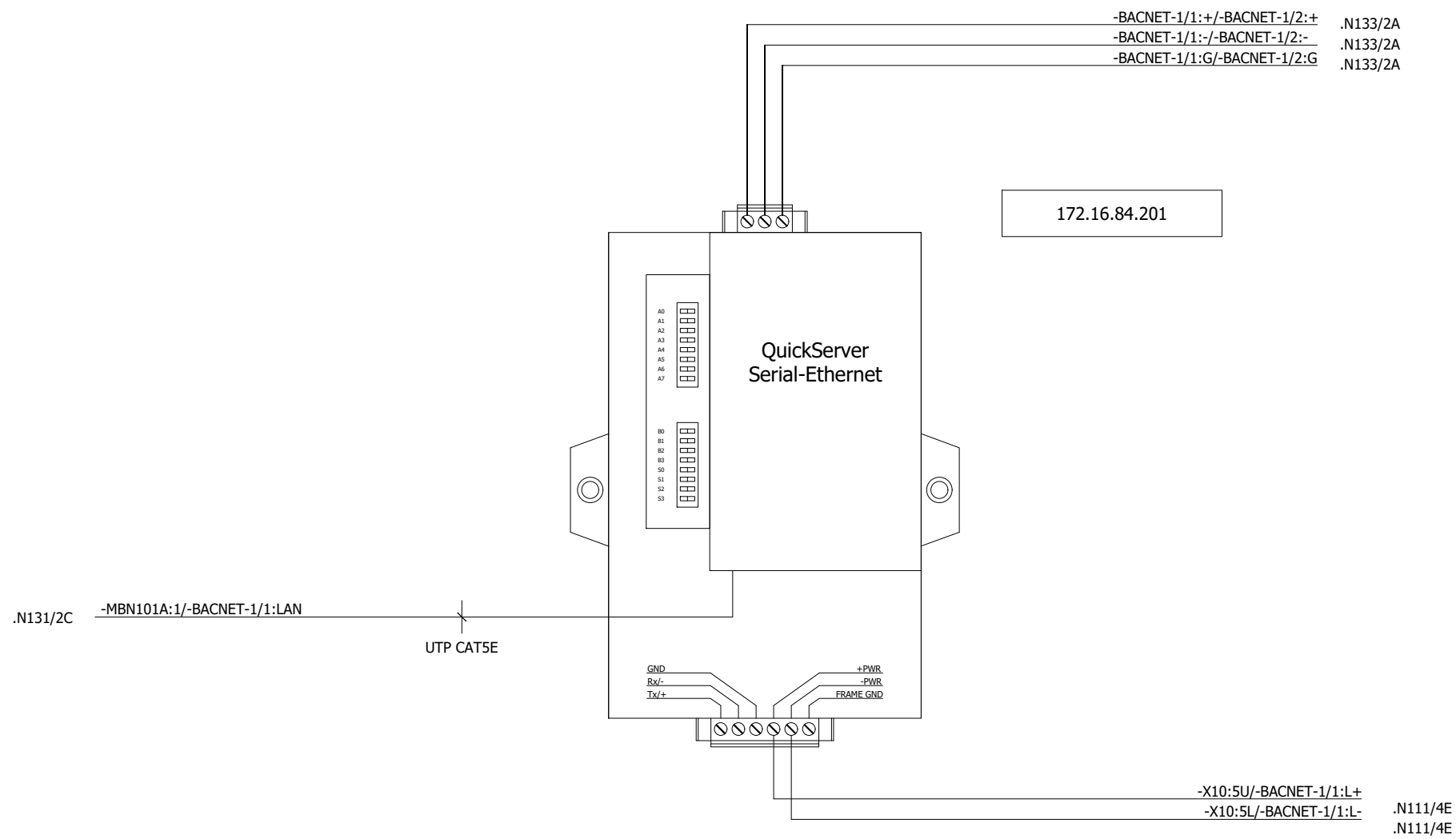

Based on	Prepared Chanwit N. / 27-03-18
Customer Site Preparation Management Co., Ltd.	Approved Atchariya K. / 27-03-18
Cust. Doc. No.	Project name Building Automation System
ABB Ref. No.	for the Excise Department (EXC)

Title BACNET-1/1
ABB ABB Limited (Thailand)

= CONTROLLER & I/O CABINET	+ DDC.-1/1	Date 27-03-18
Resp. dept. IA	Rev. 0	Sheet N132
Doc. No. 3BTH25117203-000A12		Cont. N133

We reserve all rights in this document and in the information contained therein. Reproduction, use or disclosure to third parties without express authority is strictly forbidden.

File name 3BTH25117203-000A12_N133_RO

.N132/7A	-BACNET-1/1:+/-BACNET-1/2:+	-BACNET-1/2:+/-BACNET-1/3:+	.N134/7A
.N132/7A	-BACNET-1/1:-/-BACNET-1/2:-	-BACNET-1/2:-/-BACNET-1/3:-	.N134/7A
.N132/7A	-BACNET-1/1:G/-BACNET-1/2:G	-BACNET-1/2:G/-BACNET-1/3:G	.N134/7A

172.16.84.202

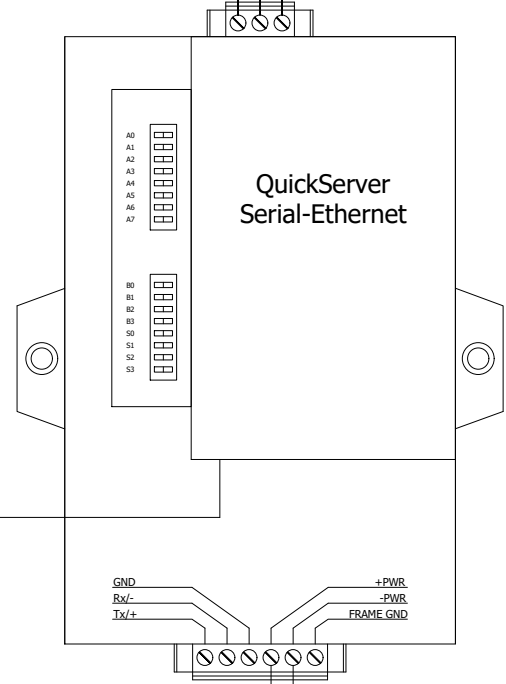

-X10:6U/-BACNET-1/2:L+ .N111/4E
 -X10:6L/-BACNET-1/2:L- .N111/4E

Based on	Customer	Site Preparation Management Co., Ltd.	Prepared	Chanwit N. / 27-03-18	Title	BACNET-1/2	= CONTROLLER & I/O CABINET + DDC.-1/1	Rev. 0	Date	27-03-18		
	Cust. Doc. No.	ABB Ref. No.	Approved	Atchariya K. / 27-03-18								
			Project name	Building Automation System for the Excise Department (EXC)	Doc. No.	3BTH25117203-000A12					Sheet	N133
ABB Limited (Thailand)												

We reserve all rights in this document and in the information contained therein. Reproduction, use or disclosure to third parties without express authority is strictly forbidden.

File name 3BTH25117203-000A12_N134_RO

.N133/7A	-BACNET-1/2:+/-BACNET-1/3:+	-BACNET-1/3:+/-XMGATE-1/1:1	.N135/6E
.N133/7A	-BACNET-1/2:-/BACNET-1/3:-	-BACNET-1/3:-/XMGATE-1/1:2	.N135/6E
.N133/7A	-BACNET-1/2:G/-BACNET-1/3:G	-BACNET-1/3:G/-XMGATE-1/1:3	.N135/6E

172.16.84.203

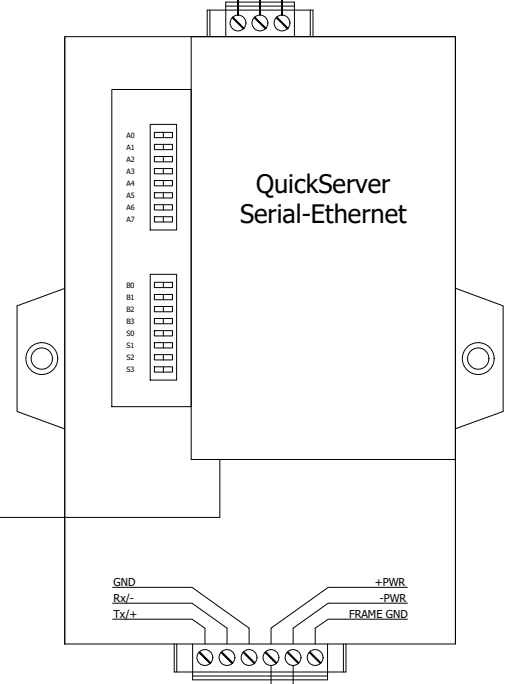

.N131/2D -MBN101A:2/-BACNET-1/3:LAN
UTP CAT5E

-X10:7U/-BACNET-1/3:L+ .N111/4E
-X10:7L/-BACNET-1/3:L- .N111/4E

Based on	Prepared Chanwit N. / 27-03-18
Customer Site Preparation Management Co., Ltd.	Approved Atchariya K. / 27-03-18
Cust. Doc. No.	Project name Building Automation System
ABB Ref. No.	for the Excise Department (EXC)

Title BACNET-1/3
ABB ABB Limited (Thailand)

= CONTROLLER & I/O CABINET	+ DDC.-1/1
Resp. dept. IA	Rev. 0
Doc. No.	Date 27-03-18
3BTH25117203-000A12	Sheet N134
	Cont. N135

We reserve all rights in this document and in the information contained therein. Reproduction, use or disclosure to third parties without express authority is strictly forbidden.

File name 3BTH25117203-000A12_N135_RO

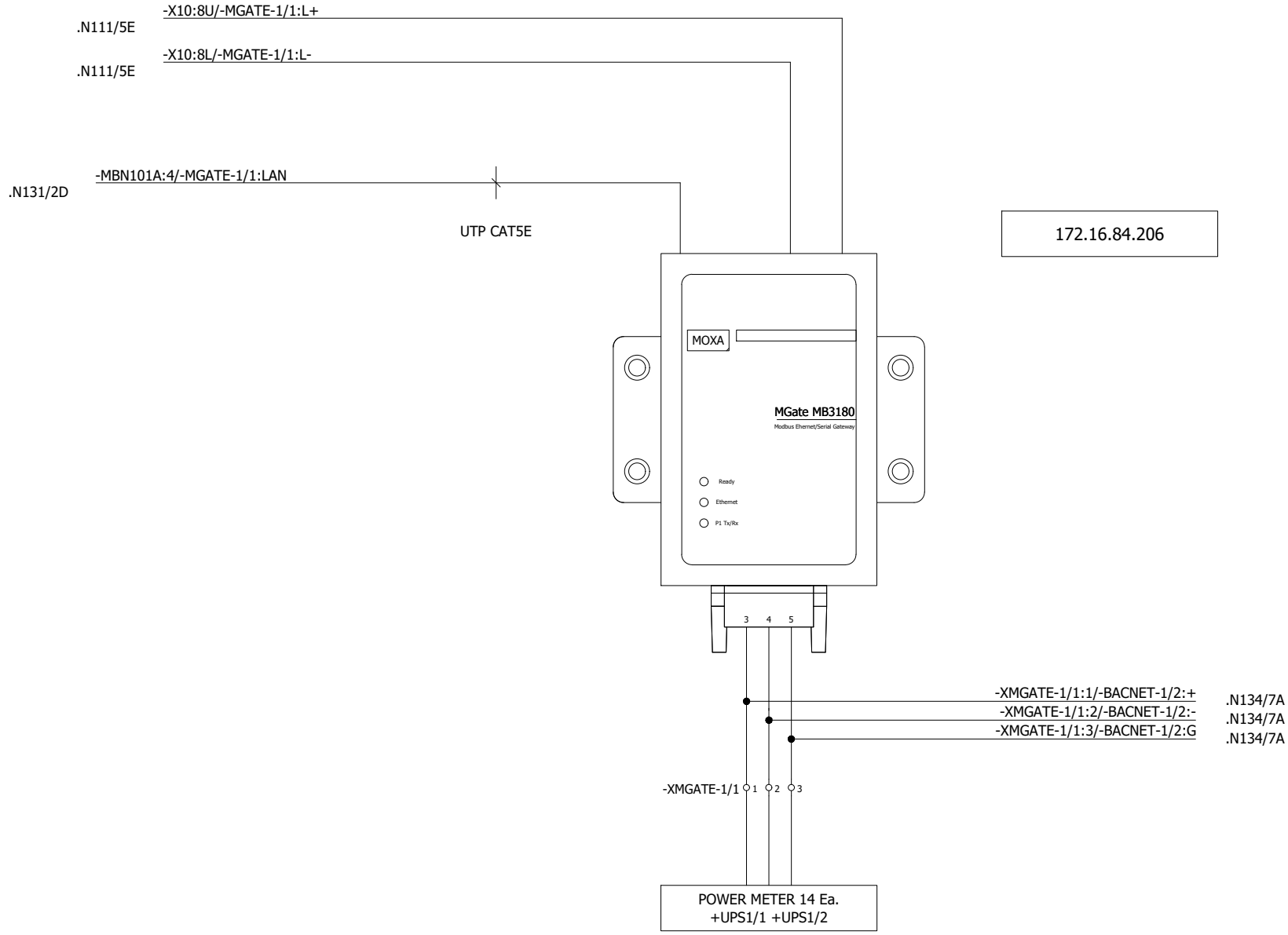

Based on	Prepared Chanwit N. / 27-03-18
Customer Site Preparation Management Co., Ltd.	Approved Atchariya K. / 27-03-18
Cust. Doc. No.	Project name Building Automation System
ABB Ref. No.	for the Excise Department (EXC)

Title	MGATE-1/1
ABB ABB Limited (Thailand)	

= CONTROLLER & I/O CABINET		+ DDC.-1/1	
Resp. dept.	IA	Rev.	0
Doc. No.	3BTH25117203-000A12	Date	27-03-18
		Sheet	N135
		Cont.	N136

We reserve all rights in this document and in the information contained therein. Reproduction, use or disclosure to third parties without express authority is strictly forbidden.

File name 3BTH25117203-000A12_N136_R0

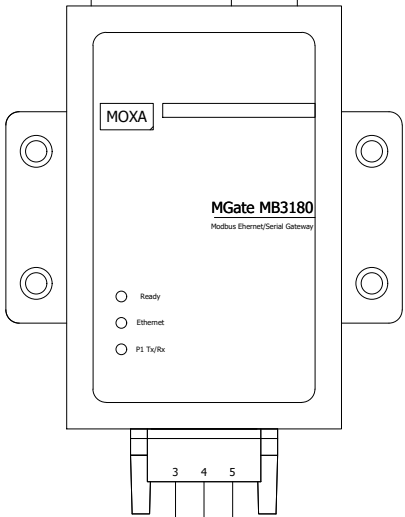
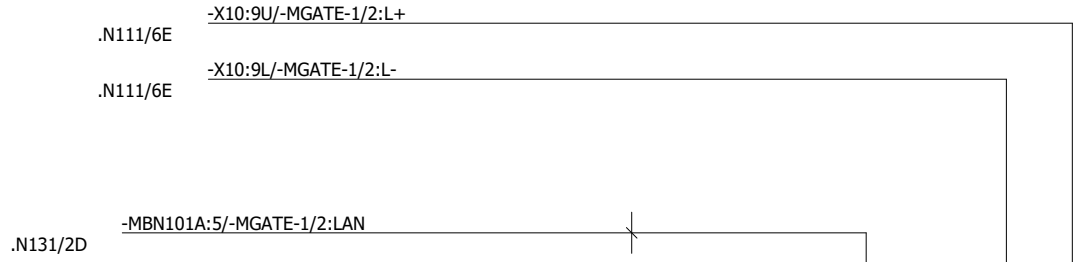

172.16.84.206

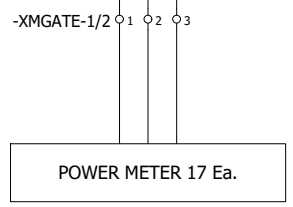

Based on	Prepared Chanwit N. / 27-03-18
Customer Site Preparation Management Co., Ltd.	Approved Atchariya K. / 27-03-18
Cust. Doc. No.	Project name Building Automation System
ABB Ref. No.	for the Excise Department (EXC)

Title	MGATE-1/2
-------	-----------



= CONTROLLER & I/O CABINET		+ DDC.-1/1	
Resp. dept.	IA	Rev.	0
Doc. No.	3BTH25117203-000A12	Date	27-03-18
		Sheet	N136
		Cont.	N141

We reserve all rights in this document and in the information contained therein. Reproduction, use or disclosure to third parties without express authority is strictly forbidden.

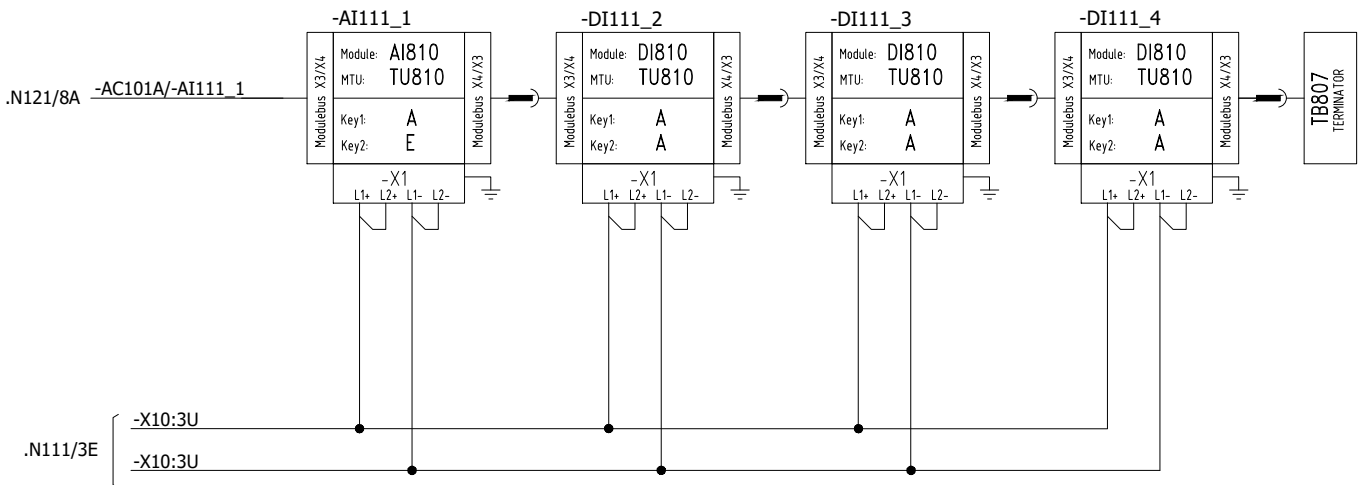

File name 3BTH25117203-000A12_N141_R0

Based on	Prepared Chanwit N. / 27-03-18
Customer Site Preparation Management Co., Ltd.	Approved Atchariya K. / 27-03-18
Cust. Doc. No.	Project name Building Automation System
ABB Ref. No.	for the Excise Department (EXC)

Title	MODULE CONNECTION
ABB ABB Limited (Thailand)	

= CONTROLLER & I/O CABINET		+ DDC.-1/1	
Resp. dept.	IA	Rev.	0
Doc. No.	3BTH25117203-000A12	Date	27-03-18
		Sheet	N141
		Cont.	N151

We reserve all rights in this document and in the information contained therein. Reproduction, use or disclosure to third parties without express authority is strictly forbidden.

File name 3BTH25117203-000A12_N151_RO

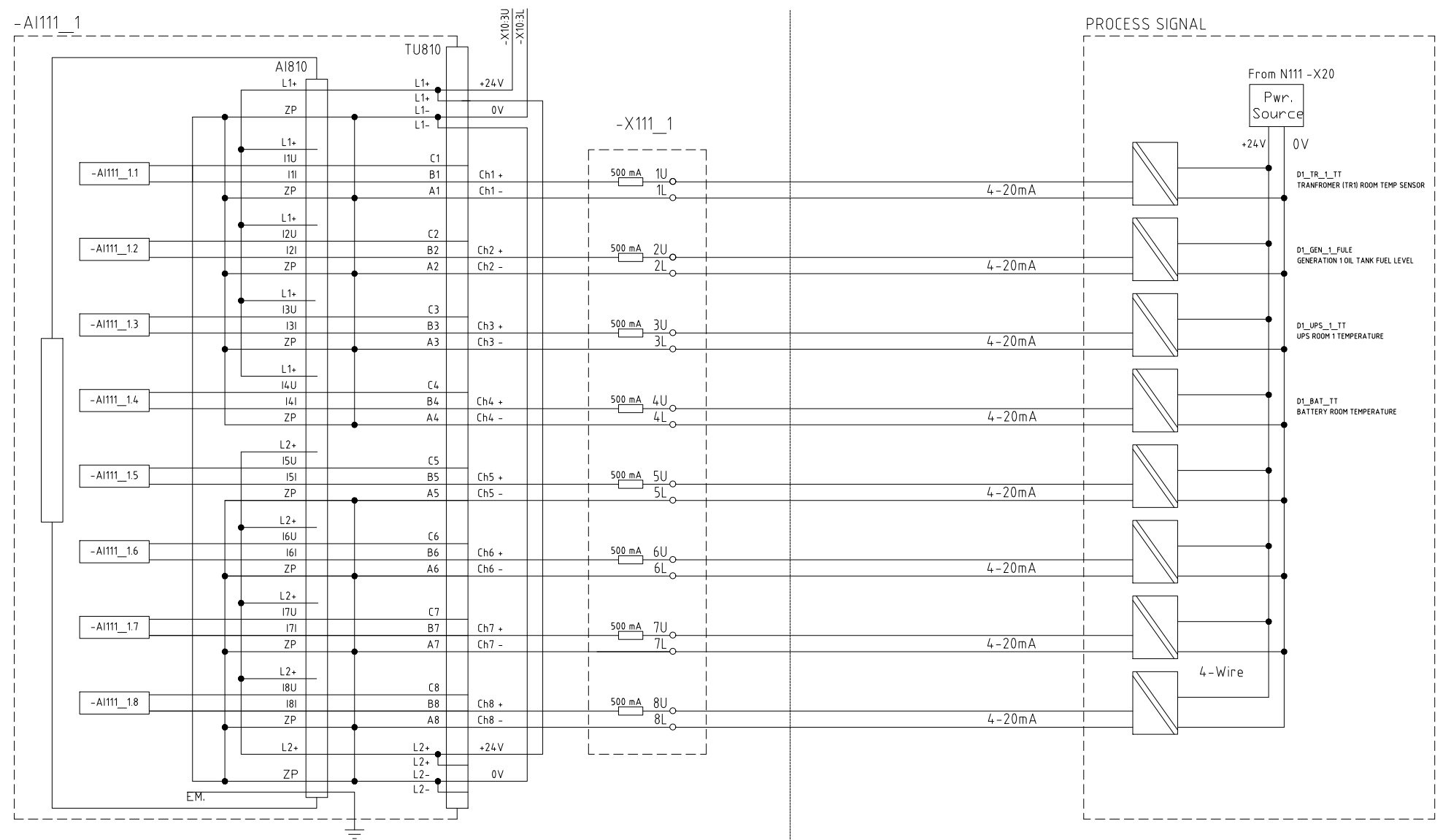

Based on	Prepared Chanwit N. / 27-03-18
Customer Site Preparation Management Co., Ltd.	Approved Atchariya K. / 27-03-18
Cust. Doc. No.	Project name Building Automation System
ABB Ref. No.	for the Excise Department (EXC)

Title ANALOG INPUT AI810 & TU810
ABB ABB Limited (Thailand)

= CONTROLLER & I/O CABINET	+ DDC.-1/1
Resp. dept. IA	Rev. 0
Doc. No.	Date 27-03-18
3BTH25117203-000A12	Sheet N151
	Cont. N152

We reserve all rights in this document and in the information contained therein. Reproduction, use or disclosure to third parties without express authority is strictly forbidden.

File name 3BTH25117203-000A12_N152_RO

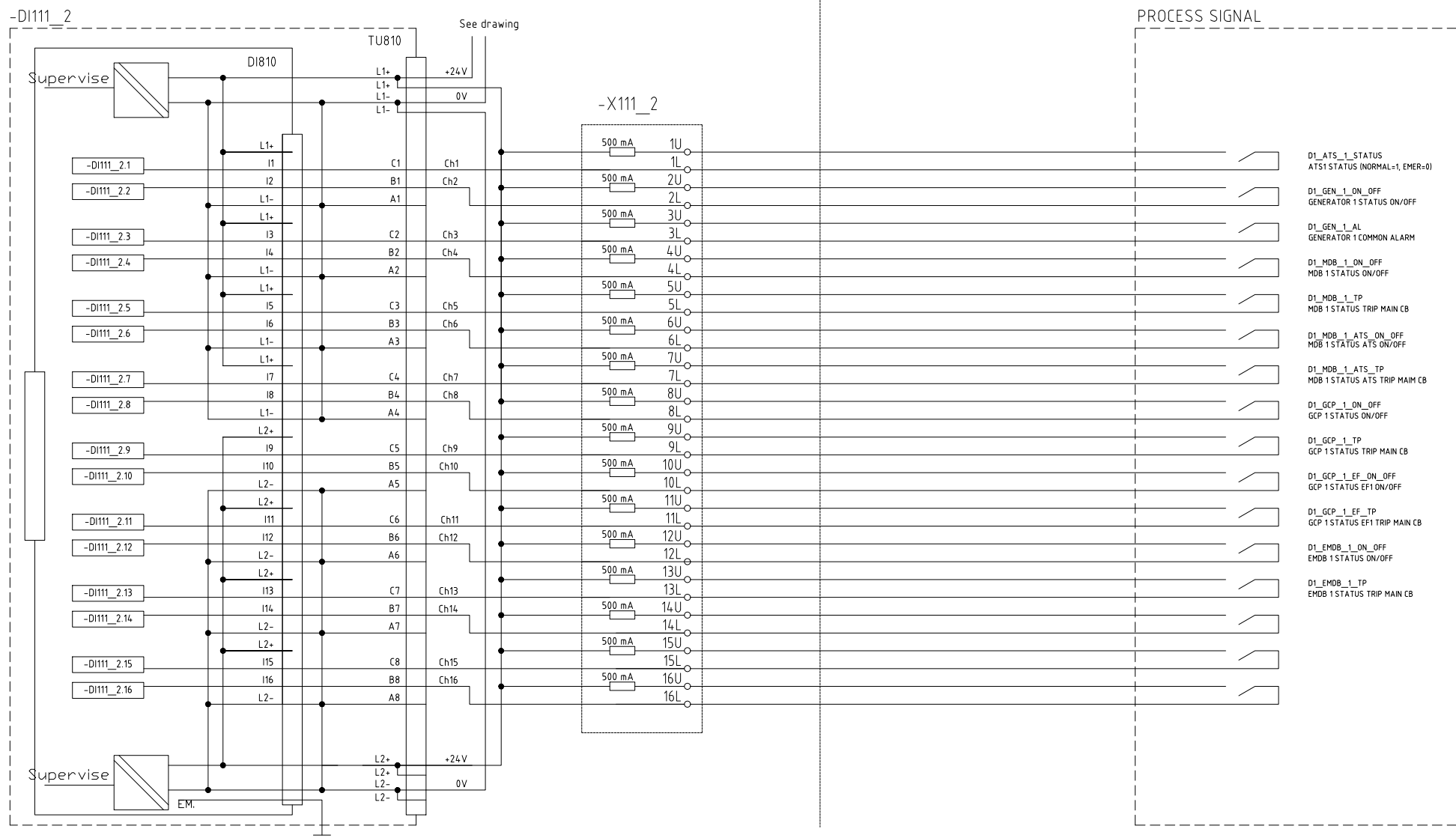

Based on	Prepared Chanwit N. / 27-03-18
Customer Site Preparation Management Co., Ltd.	Approved Atchariya K. / 27-03-18
Cust. Doc. No.	Project name Building Automation System
ABB Ref. No.	for the Excise Department (EXC)

Title	DIGITAL INPUT DI810 & TU810
ABB ABB Limited (Thailand)	

= CONTROLLER & I/O CABINET		+ DDC.-1/1	
Resp. dept. IA	Rev. 0	Date	27-03-18
Doc. No.		Sheet	N152
		Cont.	N153

3BTH25117203-000A12

We reserve all rights in this document and in the information contained therein. Reproduction, use or disclosure to third parties without express authority is strictly forbidden.

File name 3BTH25117203-000A12_N153_RO

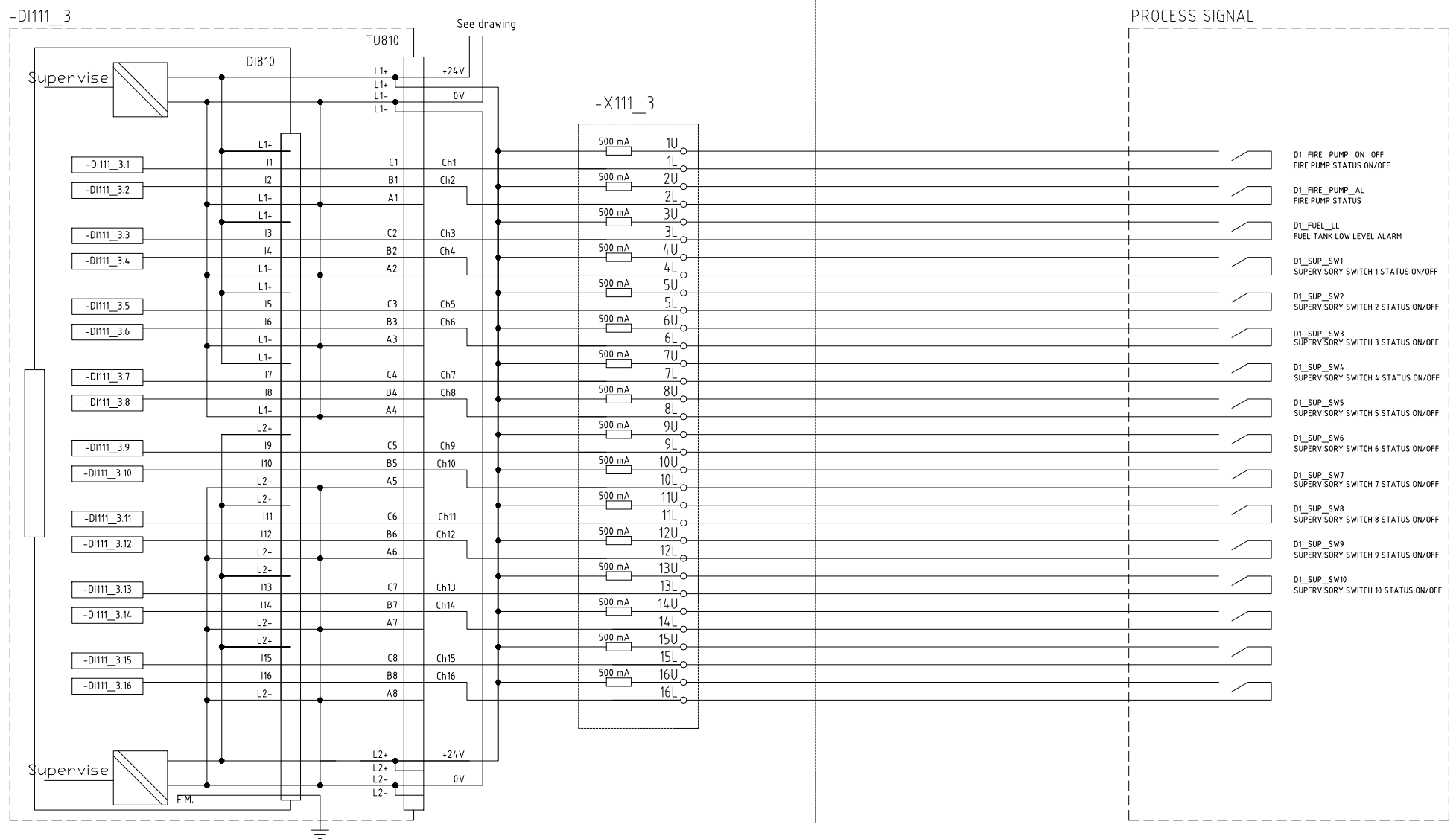

Based on	Prepared Chanwit N. / 27-03-18
Customer Site Preparation Management Co., Ltd.	Approved Atchariya K. / 27-03-18
Cust. Doc. No.	Project name Building Automation System
ABB Ref. No.	for the Excise Department (EXC)

Title DIGITAL INPUT DI810 & TU810
ABB ABB Limited (Thailand)

= CONTROLLER & I/O CABINET	+ DDC.-1/1
Resp. dept. IA	Rev. 0
Doc. No.	Date 27-03-18
3BTH25117203-000A12	Sheet N153
	Cont. N154

We reserve all rights in this document and in the information contained therein. Reproduction, use or disclosure to third parties without express authority is strictly forbidden.

File name 3BTH25117203-000A12_N154_RO

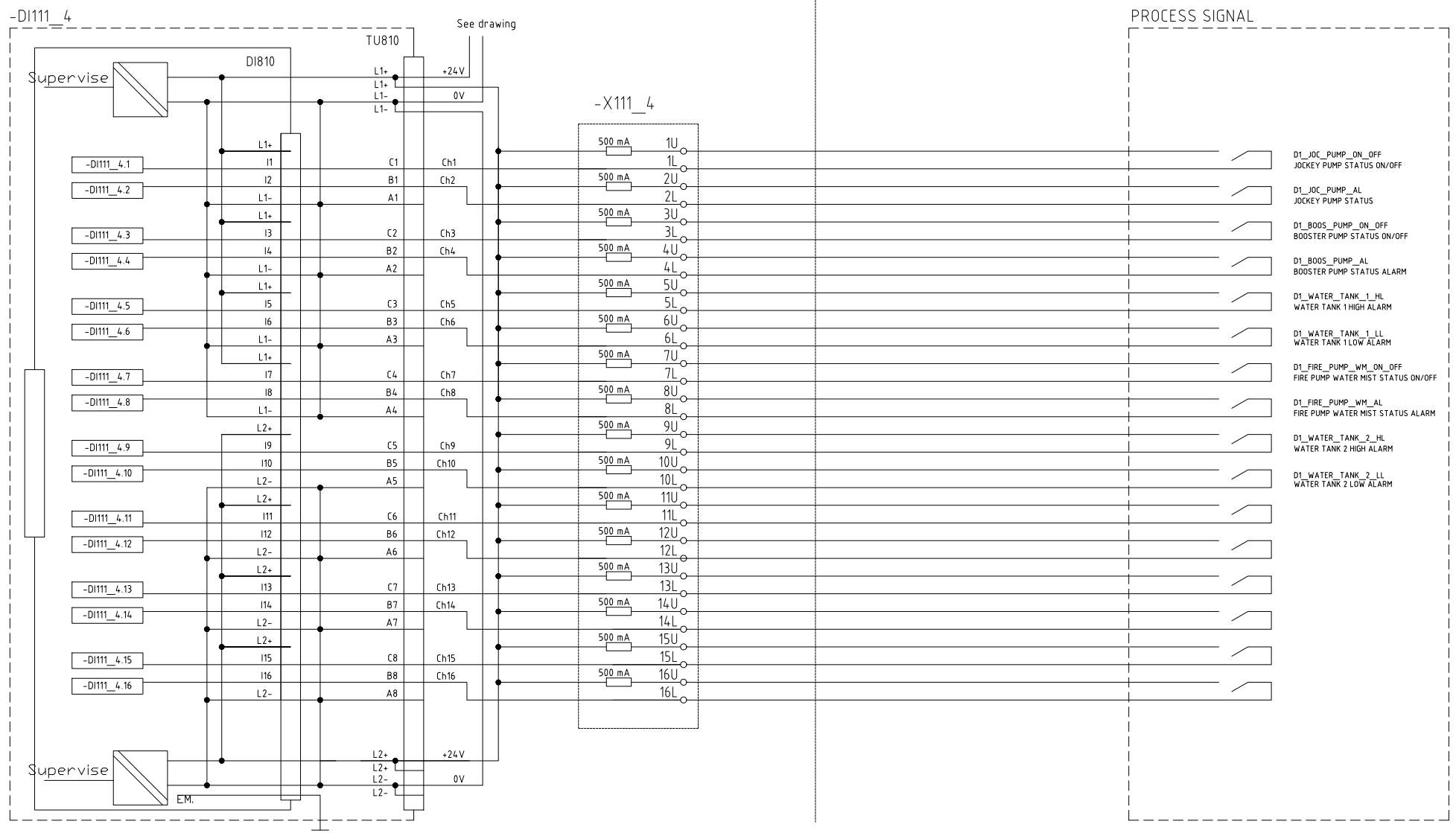

Based on	Prepared Chanwit N. / 27-03-18
Customer Site Preparation Management Co., Ltd.	Approved Atchariya K. / 27-03-18
Cust. Doc. No.	Project name Building Automation System
ABB Ref. No.	for the Excise Department (EXC)

Title DIGITAL INPUT DI810 & TU810
ABB ABB Limited (Thailand)

= CONTROLLER & I/O CABINET	+ DDC.-1/1
Resp. dept. IA	Rev. 0
Doc. No.	Date 27-03-18
3BTH25117203-000A12	Sheet N154
	Cont. -